

CORNELL • HHMI



# Cornell Institute for Biology Teachers

Copyright Cornell Institute for Biology Teachers, 1991.

This work may be copied by the original recipient from CIBT to provide copies for users working under the direction of the original recipient. All other redistribution of this work without the written permission of the copyright holder is prohibited.

Lab issue/rev. date: 6/30/08

**Title:**

**Using Protein Gel Electrophoresis to Study Evolution**

**Authors:**

Marcia Cordts and Meredith Kusch, Cornell University, Ithaca, NY

Nancy Ridenour, Ithaca High School, Ithaca, NY

Mary Colvard, Cobleskill High School, Cobleskill, NY

Edited by Edward Cluett, Emily Fawcett and Mike Yerky, Cornell University, Ithaca, NY

**Appropriate Level:**

Life Science, High School, Honors, or Advanced Placement Biology

**Abstract:**

Students will separate a mixture of proteins from skeletal muscle using SDS-polyacrylamide gel electrophoresis (PAGE). PAGE is a powerful analytical technique having numerous applications in modern biology. Evidence for evolutionary relatedness amongst organisms can be determined using this technique. Suggested organisms to compare include various fishes, mammals, poultry and/or sea foods, all of which are available from the grocery store. During the laboratory, students will develop an experimental design, prepare samples of muscle tissue from various organisms, observe the process of electrophoresis and analyze their results. Analysis consists of comparing protein bands according to their molecular weights on the gel.

**Time Required:**

Teacher Prep: Significant, includes a trip to the grocery store

Student Time: Either a full day in-school field trip or four 45 min. class periods; if the second option is chosen, either the teacher or students need to be available between classes and/or after school to turn off the gels and prepare them for staining at the end of the third day.

**Living Environment:**

**1-Inquiry, analysis, design:** 1-Purpose of scientific research: 1.1a,(b), 1.2a,b,1.3a,b, 1.4a; 2-Research plan, hypothesis: 2.1, 2.3all, 2.4; 3-Analysis of results: 3.1a, 3.3, 3.4; **4-Content:** 1-Living things: 1.2a; 2-Genetics: 2.1g,i, (j); 3-Evolution: 3.1a,e,k; 6-Ecology: 6.2a

# Additional Teacher Information

## Information with which students must be familiar

- The structure and function of proteins, including what polypeptides are.
- Principles of electrophoresis.
- An understanding of evolution at the molecular level.
- Micro-scale units of measure.

## Time required

**Before class:** Ordering of proper equipment and supplies. 1-2 hours to make up all the solutions and put out supplies. A trip to the grocery store to obtain meat samples.

**In class:** As written, this lab is designed to be done in one full day (4-6 hours) with one 45 min. class period for analysis and follow up. You can use the down time (e.g., when the gels are running and staining) for lecture/discussion on electrophoresis, proteins and/or molecular evolution, or you could do other labs or activities. You can also do the lab in four 45 minute class periods.

**Day 1:** Background information and experimental design.

**Day 2:** Extraction of muscle protein from animal tissues (the “master supply tubes” may be stored in the refrigerator overnight or in the freezer for longer time periods).

**Day 3:** Gel electrophoresis.

**Day 4:** Observation, analysis and follow up. If you have double periods (80-90 minutes) available for labs, you should consider combining the Extraction and Gel electrophoresis portions into one double period. If you choose one of these multi-day options, someone needs to be available between class periods and after school the day the gels are loaded to turn off the gels and do the staining procedure.

## Materials

### Expendables

2 bottles blue Tris-SDS solubilization buffer, may be labeled “Laemmli Buffer” (per 4 gels)

1 bottle of protein-fixative stain (per 4 gels)

1 bottle w/ ~ 90 ml 10x Tris-Glycine-SDS running buffer (per 4 gels)

*The following two items are shipped separately:*

Precast polyacrylamide gels (**refrigerate upon arrival - DO NOT FREEZE!**)

1 vial of high molecular weight markers (**freeze upon arrival**) (per 4 gels)

**Protein Gel Electrophoresis apparatus:** (The number of electrophoresis setups required will vary depending on class size).

Mini vertical gel boxes w/ loading guides and buffer dams. Each box holds two gels.

1 Thermometer

Power supplies and extra fuses

Staining trays with lids

Micropipettors (2-20 $\mu$ l) w/ pipet tips

1 Dry bath heater

**General Lab Supplies** (\* Items are **NOT** supplied in the CIBT Protein Kit)

\* 500 ml or 1 liter flask or beaker (one per gel box)

\* Labeling tape

\* 100 ml graduated cylinder (at least one per class)

\* 4 markers

\* 500 ml graduated cylinder (at least one per class)

\* Razor blades or scalpels (1/meat sample)

15 ml blue-capped plastic tubes

Cutting boards and glass or plastic rods

Test tube racks

\* 1 spatula

\* Clinical centrifuge or may be substituted by a funnel with cheesecloth (one for whole class) – alternatively, let gravity work overnight in the refrigerator

\* Safety goggles

Microcentrifuge tubes

\* Transfer pipettes (1 per meat sample plus one for Laemmli Buffer and distilled water)

Microcentrifuge racks

\* Latex gloves

**Optional supplies**

\* Digital camera

\* Light box for viewing gels (an overhead projector with an opaque cover would work also)

**Preparation Instructions**

- The gels should be stored in a refrigerator, **do not** freeze the gels.
- Gloves should be used at all times when handling the gels.

- To prepare the gels the day of the lab, cut the gel packets open over the sink or a container, drain out excess buffer, and throw away the filter paper and plastic pouch. Then use a razor blade to cut along the black line on the bottom front of the gel cassette, and peel off the strip of plastic covering the bottom front of the gel. This exposes the gel to electric current. You can leave the gel cassettes at room temperature in a tray of buffer or distilled water until the students are ready to load them.
- The molecular weight markers (also referred to as the size standard) come in a 1.5 ml microcentrifuge tube, often labeled “Prot. std.” One tube has enough marker for 4 gels. You should store this tube in the freezer until the students begin preparing their gels for electrophoresis.
- When purchasing meats, keep in mind that you only need a very small amount of each sample. The deli section at your grocery store will usually give you small samples for minimal or no charge. Be sure to keep track of which meat is which. **Note:** you need two sets of 15 ml conical tubes, one set for steps 4-7 of the sample preparation, and a new set for steps 8-10!
- All chemicals should be prepared according to the manufacturer’s directions. The Tris-Glycine-SDS running buffer is supplied as a 10X concentrate. The buffer will be sudsy because it contains SDS. The students will add 40 ml of this 10X buffer and 360 ml of distilled water in a 500 ml graduate cylinder to produce 400 ml of 1X buffer, which is enough for one gel box. The bottle contains about 90 ml of 10X running buffer, enough for four gels.
- The blue Tris-SDS solubilization buffer (often labeled Laemmli Buffer) is a 4X stock solution. The students dilute it to 1X when they add 3 ml of distilled water to their samples; **do not** dilute this before hand.
- The stain is not reusable. You should pour it down the sink with water.

## Safety Precautions

Good laboratory practice should be followed while carrying out all aspects of this lab. Students should be required to wear gloves and safety glasses while handling the meats, the polyacrylamide gels, the protein stain and the other chemicals. Be sure that students wash their hands and bench tops after working with the raw meats, especially if you purchase chicken or seafood.

## Helpful Hints

- The ideal group size is four students per gel, but 2-6 students will also work.
- All of the materials in the CIBT kits are available commercially. You can order them all from Bio Rad or WARD’S. The gel boxes and gels can be ordered from Bio Rad. If you order materials from another source, be sure to make necessary modifications due to differences in equipment/product.
- The questions the students ask will depend on the meats available. In addition to grocery store meats, other samples can be used. For instance, one teacher went to a French restaurant and obtained frog legs. Possible questions/ experimental designs include:
- Years ago, an advertising campaign called pork “the other white meat”? Is its protein composition more similar to chicken or to beef?

- What is imitation crab made of? (For this you might want to have students compare imitation crab to chicken, several species of fish and crab legs. Crab legs are not available year round; you can substitute shrimp and tell students that shrimp, like crab is a crustacean. If imitation crab is made from something similar to crab it should have a protein composition similar to shrimp.)
- Broad level phylogenetic comparisons
- Similarities and differences between fresh water and salt water fish
- Land animals vs. sea animals
- Vertebrates vs. invertebrates
- Provide the students with a mystery meat and have them classify it. Avoid highly-processed or cooked meats; they may contain non-muscle proteins. You also do not want ground meats as the fat in it interferes with the electrophoresis.
- There are 15 lanes available for loading. However, if you use the loading guides, only lanes 2-14 are easy to load. It works well to have each team choose 5-7 samples. Two teams of two students can share a gel. Make sure that each available sample gets loaded at least twice across all gels so that within the class there will be duplicates of each sample. Make sure at least one lane contains molecular weight markers, but pick a lane off to the side to help to orient the gel after it gets flipped during removal and staining/destaining.
- Please refer to the addendum “Gel Box Assembly” when setting up the gel boxes and inserting the gels. **It’s especially important to remember to press down on the top of the electrode and the two gel plates assembly while closing the two cam levers on the clamping frame.** Otherwise buffer may leak from the inner chamber, interrupting electrophoresis. If you notice the level of the buffer in the inner chamber is too low, stop the run, carefully lift the lid and top of the inner chamber with excess buffer.
- Students can write their names on the long plate to identify the gels.
- Remove the comb from the top of the gel using two hands just before loading. Use a transfer pipette to rinse out the wells.
- Samples should be pipetted carefully but quickly into the wells at the top of the gel. Since there are two gels to a box, one group of students may have to wait to load their gel until the first group is finished. If too much time is spent between loading the first sample and turning on the current, diffusion of proteins will occur and the protein bands may not show as nicely. **Don’t move the gel boxes after samples have been loaded.**
- If you are running an odd number of gels, insert one of the buffer dams instead of a gel into the other side of the clamping frame, so that the inner buffer chamber will be sealed.
- Some meats, such as clam or squid, are hard to mash. Mincing the samples into **very tiny pieces** is the key to success.
- A 15% polyacrylamide gel used in this lab should run for 35-45 min to show the best distribution of intact proteins.

- Gels will destain much more quickly and effectively if 30% methanol is used as the first destain. Shaking or rocking the gels will speed up the destaining process.
- Caution should be used when working with the gels during staining/destaining. The gels are very fragile and rip easily.
- The size standard is measured in daltons. A dalton is the unit of measure of molecular weight. One dalton is equivalent to the weight of one hydrogen atom. One amino acid weighs, on average, 120 daltons. So, you can approximate the number of amino acids in a protein based on its molecular weight. You can introduce this concept to more advanced students and use it in pre-lab question #2 and the optional post-lab question #7.
- Advanced students would benefit from doing the CIBT lab *Biological Shapes* prior to doing this lab.
- If you have covered the proteins in motor muscle, you can discuss that topic in relation to this lab. For example, you should see a band at 46 kd in all of your muscle samples. This band represents actin. All animals, both invertebrate and vertebrate, have actin as a primary component in their muscle. Myosin, the second major muscle protein, is very large and does not separate well on the gels we are using. It is found in the prominent band at the top of every lane.

## FAQ

1. Can you stain the gel a day after the lab is over? Yes, you can do one of two things:
  - A) If they are still in their cases you can simply put them inside a Tupperware, close it and then store in the refrigerator. The gels will not dry up.
  - B) If they have been taken out of the gel plates, then put them in Tupperwares with some distilled water, close them and then store in the fridge. There is a chance that some of the bands will disappear, but this keeps them from drying up.
2. How do I get the gel ready?  
See instructions on page 4 (teacher section)
3. The inner chamber inside the gel box is leaking, what do I do?  
See page 5 (teacher section)
4. When and how do I take the gel out of the case?  
See page 6 (student section)

## Answers to pre-lab questions

1. Why do SDS-coated polypeptides separate when placed in an electrical field?

*Because they are coated with SDS, polypeptide samples prepared for SDS gels have a net negative charge. When they are placed in the electrical field, they will migrate toward the positive electrode. The gel is a restrictive material through which small molecules will pass more readily than large molecules. Polypeptides of higher molecular weight will therefore be found closer to the wells than smaller molecules which will move further down the gel during electrophoresis.*

- 2a. On the diagram below, sketch the predicted results if lane #1 was loaded with a sample composed of 4 different types of polypeptides (having 100 amino acids, 175 amino acids, 250 amino acids, 300 amino acids), lane #2 was loaded with a sample composed of 3 types of polypeptides (200 amino acids, 250 amino acids, and 350 amino acids) and lane #3 was loaded with a sample of 5 different types (100 amino acids, 150 amino acids, 175 amino acids, 250 amino acids, 300 amino acids).

Note: The average amino acid has a molecular weight of 120 daltons. Therefore, more advanced students could be asked to compare the information above to a molecular weight standard in lane 4, the picture below includes the molecular weight standard.

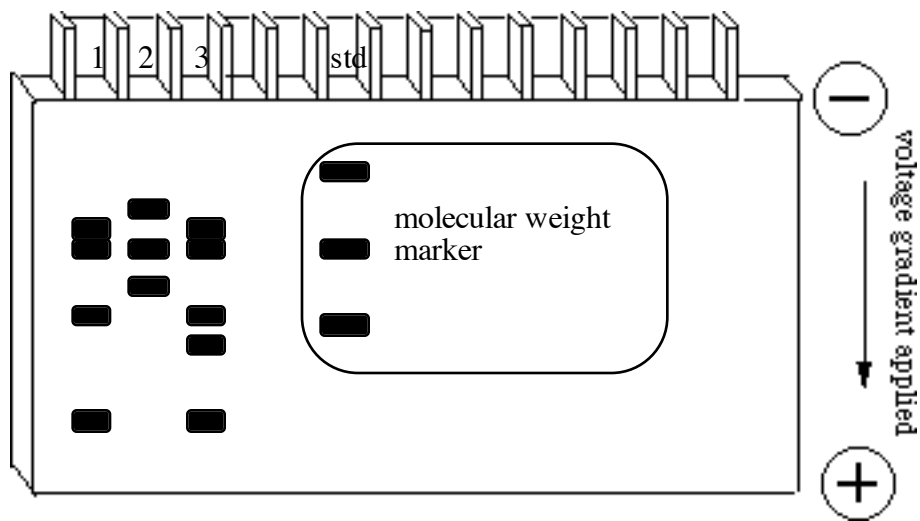

- b. If each lane represents the proteins from a different species of animal, which two would you say are the most closely related? Why?

*Organisms 1 and 3, because their protein composition is the most similar. They share a large number of bands.*

3. If two proteins have the same molecular weight, are they necessarily the same protein?

*No, many unrelated proteins have the same molecular weight. However, if two organisms exhibit a number of proteins of the same molecular weight, it becomes increasingly likely that those proteins are similar.*

### Answers to post-lab questions

1. Restate the question your group was asking.

*Answers here will vary depending on the experimental design.*

2. Describe or sketch the appearance of the gel initially.

*In each well there is some blue material that is visible on top of the gel. In some wells this blue material is very faint.*

3. Describe or sketch the appearance of the gel after 5 minutes. Explain the difference between the “just loaded” gel and the gel after 5 minutes.

*After five minutes the blue material has moved down into the gel. It is now below the black rubber gasket. The protein dye has a negative charge and has started moving towards the anode.*

4. Observe the bands on the gel and make a sketch of your gel. Be sure to indicate the positive and negative sides of the gel and label each lane indicating which sample was loaded into it.

*Answers here will vary depending on the protein samples used.*

- 5a. Based on your analysis of the gel, which organisms are closely related?

*Answers here will vary depending on the protein samples used.*

- b. Which organisms are distantly related? How do you know?

*Answers here will vary depending on the protein samples used. Closely related samples will have many bands located at the same location at a similar concentration.*

6. Discuss the results of your experiment in light of the questions you have asked?

*Answers here will vary depending on the experimental design.*

7. It is possible to determine the size of individual proteins by comparing their distance migrated on a gel to the distances moved by proteins of known size. The distance migrated is inversely related to the log of the size.

- a. From your gel photo (or from the gel itself) measure the distance from the well to each of the bands in the lane corresponding to molecular weight markers.
- b. Obtain a piece of 2 cycle semi-log paper. For each band, plot the distance migrated from the well on the linear axis and the size (molecular weight) on the log scale. Connect the points with a smooth curve. This is a standard curve and can be used to determine the size of any of the proteins separated from your muscle tissues. Conditions vary from gel to gel, this is why it is very important to include molecular weight markers on every gel that you run. You cannot use a set of molecular weight markers from another gel in your class to determine the size of proteins on your gel. Determine the size of several of the most abundant proteins in each of your samples.
- c. An amino acid is approximately 120 daltons. Use this information to calculate the approximate number of amino acids in the proteins you sized in part b.

A 15% gel run for 50 minutes, stained 4 minutes and destained in 30% methanol. Note the pronounced bands for myosin (203,000d) and actin (46,000d) in every lane.

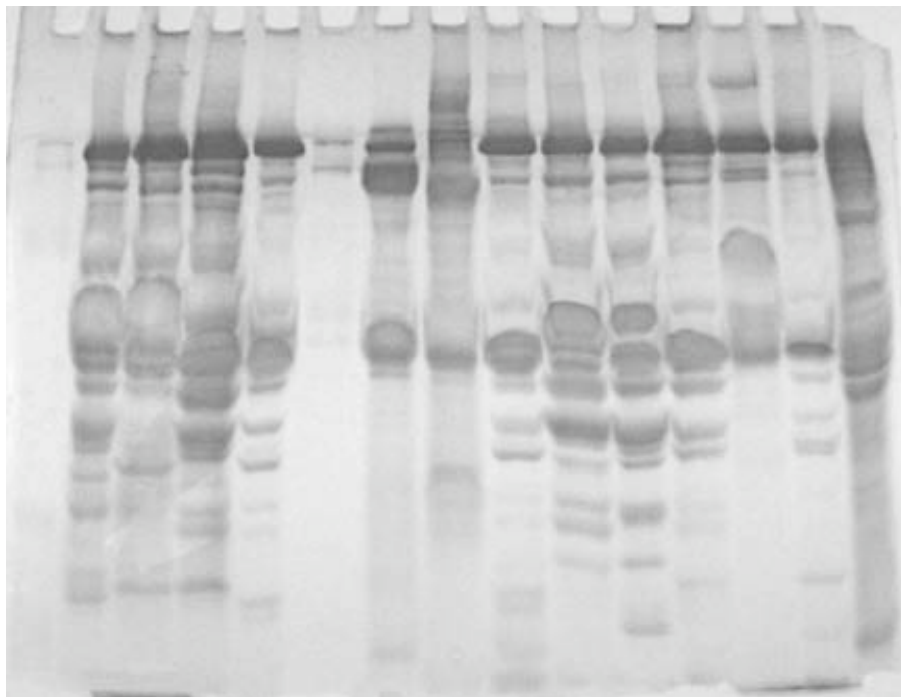

# Using Protein Gel Electrophoresis to Study Evolution

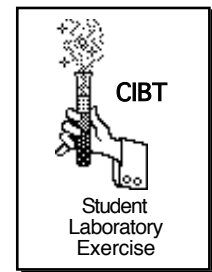

## Objectives

In this lab you will:

1. Design an experiment to investigate a question about evolutionary relatedness between organisms.
2. Prepare protein samples from grocery store meats.
3. Do protein gel electrophoresis.
4. Analyze your results in relation to the questions you chose to investigate.

## Introduction

Gel electrophoresis is a powerful research tool widely used by scientists today. Using this tool, scientists can separate a complex mixture of large molecules (macromolecules) according to their size. The two types of macromolecules most often separated by gel electrophoresis are nucleic acids and proteins. Information about the size of a molecule provides important clues as to its identity.

In this experiment, the detergent sodium dodecyl sulfate (SDS) and heat are used to denature proteins in a muscle tissue taken from different grocery store meat samples. The SDS coats the resulting polypeptides with a negative charge (see Figure 1).

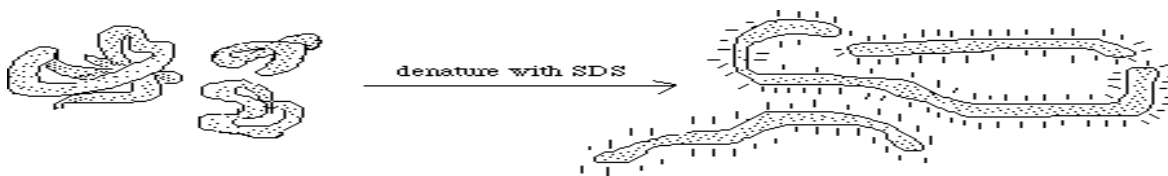

Figure 1: When three functional polypeptides (on the left) are coated with SDS and heated they lose their three-dimensional structure and take on a net negative charge (on the right). Bigger polypeptides are coated with more molecules of SDS; the ratio of molecular weight to charge is approximately the same for all proteins.

The polyacrylamide gel is placed in a gel box between two electrodes, the sample is then placed into a well at the top of the gel, and the electrodes are connected to a power supply that produces a voltage gradient across the gel. This causes the negatively-charged, SDS-coated polypeptide molecules to move towards the positive electrode (the anode). The polyacrylamide gel is composed of long molecules that

form a tangled mesh (See Figure 2). Simply put, to get through the gel, the macromolecules must make their way through a maze-like network of pores. The largest molecules move more slowly because they have a harder time negotiating the pores. The smallest molecules move fastest because they can quickly slip through the pores. As soon as the current is applied, the SDS-treated polypeptides begin their race towards the positive electrode. As time passes the smaller polypeptides begin to “pull away from” the larger ones. As a result the proteins from muscle tissue will be separated according to size. The size of a macromolecule is commonly expressed by its molecular weight which is measured in daltons.

The polypeptide molecules cannot be seen while the gel is running. If the current is left on for too long, all the proteins will run off the gel at the bottom. For this reason, a blue dye is added to the SDS solution. This blue dye is also negatively charged and drawn toward the positive electrode. Since it is a relatively small molecule (smaller than any of the polypeptides), it moves quickly through the gel. When this dye reaches the bottom of the gel it is time to turn off the current.

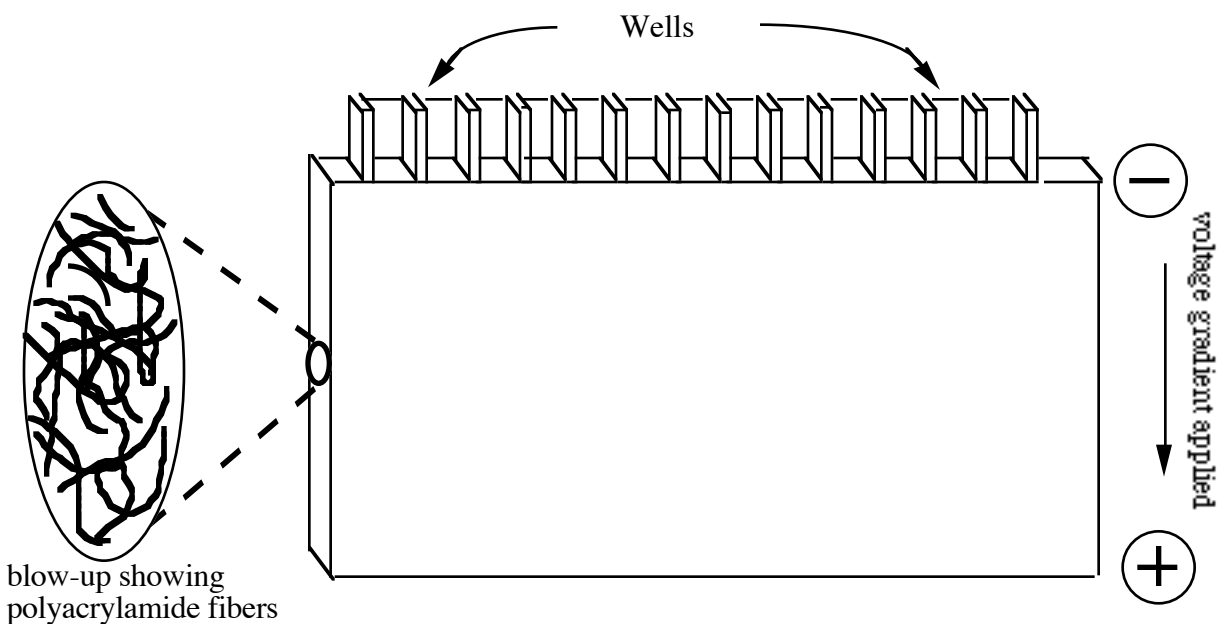

Figure 2: A simplified diagram of a polyacrylamide gel. The glass plates and supports which hold the gel upright are not shown. Mixtures of proteins can be loaded in any of the “wells” at the top of the gel, then the electric current is turned on.

After the current is turned off and the gel removed from the glass plates which hold it in place, a stain is added to the gel. This stain binds specifically to proteins and not to other macromolecules, so that wherever a dark purplish band appears on the gel, polypeptides are present. The smaller the amount of protein, the fainter the blue staining and the smaller the band. Proteins that are present in the sample in only very tiny amounts may not absorb enough stain to become visible.

The pattern of bands in each lane of the gel can provide information about evolutionary relationships between different organisms. Closely related organisms have similar gene sequences. Since proteins are synthesized according to the genetic code, closely related organisms will have similar proteins which will result in similar banding patterns on a gel. Therefore, genetic similarity can be used to make evolutionary comparisons.

## Materials

- plastic cutting boards
- transfer pipettes
- 500 ml or 1 liter flask or beaker
- gel box, loading guide, and power supply
- 2 –20  $\mu$ l micropipettors and tips
- marker and tape
- stain
- staining tray w/ lid
- glass or plastic rods
- razor blades or scalpels
- 1X Tris-Glycine-SDS running buffer
- blue solubilization (Laemmli) buffer
- 15 ml plastic tubes and rack
- microcentrifuge tubes and rack
- gloves
- distilled or deionized water
- safety glasses
- clinical centrifuge

## Safety Precautions

Good laboratory practice should be followed while carrying out all aspects of this lab. Wear gloves and safety glasses while handling the meats, the polyacrylamide gels, the protein stain and the other chemicals. Be sure to wash your hands and bench tops after working with the raw meats.

## Procedure

### Experimental Design

1. Your teacher will list the samples available to you. In the process of designing your experiment you must:
  - i. Determine what question you would like to investigate.
  - ii. Determine which protein sources you are going to use.
  - iii. Determine which sample will go in which well.
  - iv. Determine how you will interpret your results.
2. Consult with your group members and fill out the **Student Experimental Design Sheet** (page 8).
3. Your **Student Experimental Design Sheet** must be turned in to your teacher and approved before moving on to the rest of the lab.

### Sample preparation--extraction of muscle protein from animal tissues

1. Your teacher will assign your group a protein sample to prepare. You will make a protein extract for the whole class to share. This has no relation to the samples you choose to use in your experimental design.
2. Obtain a pea-sized sample of muscle tissue. Remove any skin, bone, fat or other non-muscle tissue.
3. Mince the tissue into **very tiny** pieces on the plastic cutting board using a razor blade or a scalpel.
4. Put the sample into a **labeled** 15 ml conical tube and, using a transfer pipet, add 1 ml of blue solubilization buffer (Laemmli Buffer). Mash the tissue with a rod for 1 min. With a clean transfer pipet, add 3 ml of distilled water and mash again with the rod for 1 min.
5. Place the plastic tube with the cap loosened in a dry bath set at 95°C for 5 minutes.
6. Remove your test tube from the dry bath and let it cool 2 to 5 minutes (if the protein has congealed, remash it with the rod).
7. Centrifuge the sample with the cap tightened for 5 to 10 minutes at high speed or allow the sample to settle by gravity for 1/2 hour.

*(During steps 5-7, begin steps 11&12 and start the next part of the lab, **Gel electrophoresis.**)*

8. Use a transfer pipet to draw off 0.5 ml of the supernatant and place into a new **labeled** 15 ml conical tube. Some meat samples will have a whitish layer of fat or clear oil floating on top. Avoid this layer! Insert the tip of your transfer pipette below this layer when drawing off the supernatant. Avoid the pellet, also!
9. Use a clean transfer pipette to add 1 ml blue solubilization buffer (Laemmli Buffer) and 1 ml distilled water to your new tube. Mix gently. Your original protein sample is now one fifth of the final solution.
10. Give this labeled **Master Supply Tube** to your teacher who will place all the test tubes in a rack at the front of the room. All students will obtain their samples from these tubes.
11. Obtain a microcentrifuge tube rack and microcentrifuge tubes. Label the tubes with the name of the protein samples you are going to use in your experiment. Take your rack with labeled tubes to the **Master Supply Tubes**. Add **one drop** of each protein sample to the appropriate tube.
12. Label the diagram on your **Lab Report Sheet** (Page 9) with the sequence of samples that you will use. This should be the same as your labeled diagram on your **Student Experimental Design Sheet** (Page 8).

## Gel electrophoresis

Two gels can be run in one gel box, so you may be sharing a gel box with another group. Referring to the addendum “Gel Box Assembly,” disassemble the gel box into its four parts: Lid, tank, clamping frame, and electrode assembly.

1. First, remove the lid and, using two hands, lift the clamping frame out of the tank. Then make sure to open the cam levers on the clamping frame before removing the electrode assembly.
2. Notice that one gel will fit against the green U-shaped gasket on each side of the electrode assembly. If you find a buffer dam on one side remove it, unless you are only planning to run one gel in the box. During electrophoresis, the gels will be clamped against the electrode assembly, forming an inner buffer chamber sealed off from the outer chamber in the tank. Note the location of the red anode (positive electrode) and black cathode (negative electrode). When the buffer chambers are sealed, the top of the gel will only be exposed to buffer from the inner chamber, and the bottom of the gel will only be exposed to buffer from the outer chamber.
3. **You must wear gloves** when handling the polyacrylamide gel. Obtain a gel from your teacher. The white markings on the large outside plate indicate the location of each well. This will help you locate the lanes. The actual gel itself is sandwiched between the two glass plates.
4. Insert the gels into the slots at the bottom of each side of the electrode assembly, so that the shorter glass plate on each gel faces inward, toward the green U-shaped gaskets. They will rest at an angle, with only the bottom of the gels against the gaskets.
5. Gently press the gels up against the gaskets and fit the electrode assembly into the clamping frame. Be sure to press down on the Electrode Assembly and the gel plates while closing the two cam levers on the clamping frame. This ensures a tight seal so that no buffer will leak between the inner and outer buffer chambers.

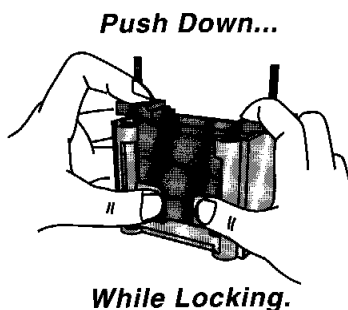

**Figure 3. Sealing the Inner Chamber**

From Bio Rad's [Ready Gel Cell Instruction Manual](#), p.5

6. Finally, set the clamping frame and electrode assembly inside the tank, so that the notches on the electrode assembly fit into the clear tabs on the tank.

7. To make 1X running buffer for each gel box, combine 40 ml of 10X Tris-Glycine-SDS Running Buffer with 360 ml of distilled H<sub>2</sub>O and mix well. Fill the inner chamber so that the buffer reaches a level between the tops of the short and long plates of the gel. Don't overfill the inner chamber, or buffer will spill over the top of the long plate, interrupting electrophoresis. Fill the outer chamber to a level just above the bottom of the two cam levers (approximately 200 ml), leave about 50 ml of buffer in the beaker in case you need to top off the inner chamber.
8. Remove the comb carefully using two hands and your index fingers. Check for bubbles in the top of the gel; these may be dislodged by a gentle stream of buffer from a transfer pipet.
9. Set the micropipettor to 10  $\mu$ l, put on a yellow tip, and draw up a muscle sample as shown by your instructor. Line up the tip with the middle of the well. **Rest** the tip on the shorter gel plate at an angle of 45°. Gently dispense the sample into the well. The sample will sink to the bottom of the well. Be certain your diagram correctly shows the lane each sample was loaded into.
10. You also need to add 10  $\mu$ l of the protein standard (molecular weight marker) to the appropriate lanes. The protein standard is a mixture of specific polypeptides of known size. By including them on the gel, you can estimate the size of the polypeptides in your sample. The molecular weight marker used here has three proteins:

<b>protein</b>	<b>molecular weight (in Daltons)</b>
Bovine serum albumin	66,000 d
Carbonic anhydrase	29,000 d
Soybean Trypsin Inhibitor	20,000 d

11. Slide the lid into position, making sure the black plug fits on the black electrode and the red plug fits on the red electrode. Attach the black and red cords to the power supply in the proper orientation, plug in the power supply, and turn the power on at 200 volts. Bubbles rising from the bottom of the tank indicate the current is running.
12. Describe or sketch the initial appearance of the gel and the appearance after 5 min. as indicated on your **Lab Report Sheet** (Post Lab Questions).
13. Run the gel for 35-45 minutes. It's important to let the bands of blue dye run off the bottom of the gel before turning off the power supply. Notice that the bottom of the gel plates extends below the green gasket on the electrode assembly. The bands of dye will be hard to see when they move in front of the gasket, but will reappear a few minutes later near the bottom of the gel. **Turn off the power supply, unplug the power cord**, and remove the lid.
14. **Wearing gloves and goggles**, pour out the used running buffer from both gel chambers. With two hands, remove the clamping frame from the tank. Make sure the inner chamber is emptied before opening the cam levers on the clamping frame, or the buffer will leak out. Then lift the electrode assembly carefully out of the clamping frame and remove the gels. To expose the gels, slice the plastic along the outside of the white spacer on one side of the gel plates. Then use the razor blade to pry the plates apart. Open the glass plates as if you were "opening a book." **Be careful!** The gel is fragile and tears easily.

15. Carefully place the gel into a dish of distilled water and allow the gel to soak for 10-15 minutes, while gently rocking.. Using a spatula to hold the gel in place, pour out the water and add enough of protein stain so that the gel is completely covered and floating in the stain. This solution precipitates the proteins, “fixing” them into place so that they cannot diffuse through the gel. In addition, it contains a dye which will stain the proteins blue.
16. Allow the gel to soak in staining solution for no more than 5 minutes, while gently rocking. The gel should be uniformly blue, but the bands will not yet be visible. However, there is no need to stain the gel for a longer period of time.
17. **Wearing gloves**, discard the stain, rinse the gel once with water, and place the gel in water to remove stain which is not bound to proteins. The water should be changed several times during this destaining process. The proteins will remain blue while the background becomes clear. The gel will probably need to destain overnight.

### **Observations and analysis**

1. Remove your gel from the Tupperware container and put it on a light box or white surface. Draw a picture of your gel and answer the post-lab questions.
2. With your teacher’s assistance, photograph your gel, using a digital camera. You may label the picture using Photoshop or similar software and submit it with your lab report.

Name: \_\_\_\_\_

Date: \_\_\_\_\_

## Student Experimental Design Sheet

What question is your group going to investigate?

What protein sources will you use?

Label the following diagram with the position of each protein you will use. Your 6th and 12th lanes should be the molecular weight standard. This will prevent confusion if the gel becomes flipped over.

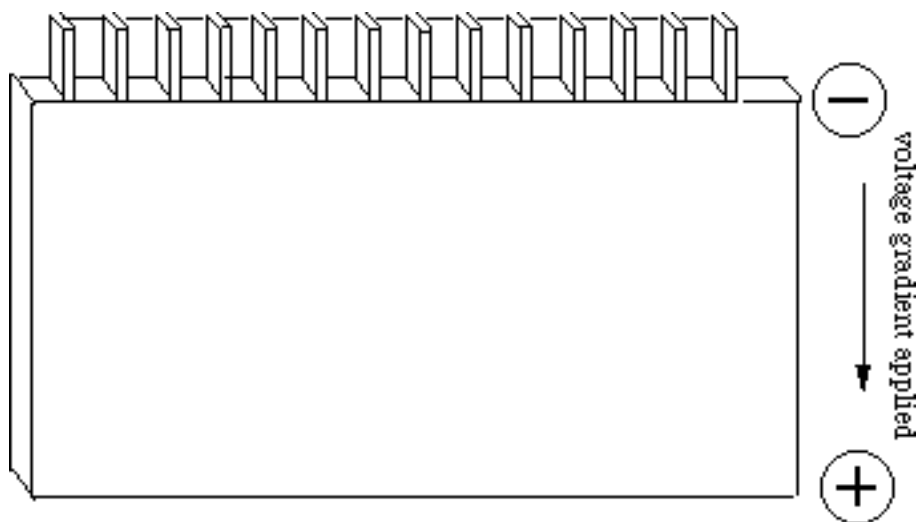

How will you analyze your results?

Name: \_\_\_\_\_ Date: \_\_\_\_\_

## Lab Report Sheet

### Pre-Lab Questions

Write all of your answers on a separate page.

1. Why do SDS-coated polypeptides separate when placed in an electrical field?
- 2a. On the diagram below, sketch the predicted results if lane #1 was loaded with a sample composed of 4 different types of polypeptides (having 100 amino acids, 175 amino acids, 250 amino acids, 300 amino acids) while lane #2 was loaded with a sample composed of 3 types of polypeptides (200 amino acids, 250 amino acids, and 350 amino acids) and lane 3 was loaded with a sample of 5 different types (100 amino acids, 150 amino acids, 175 amino acids, 250 amino acids, 300 amino acids).

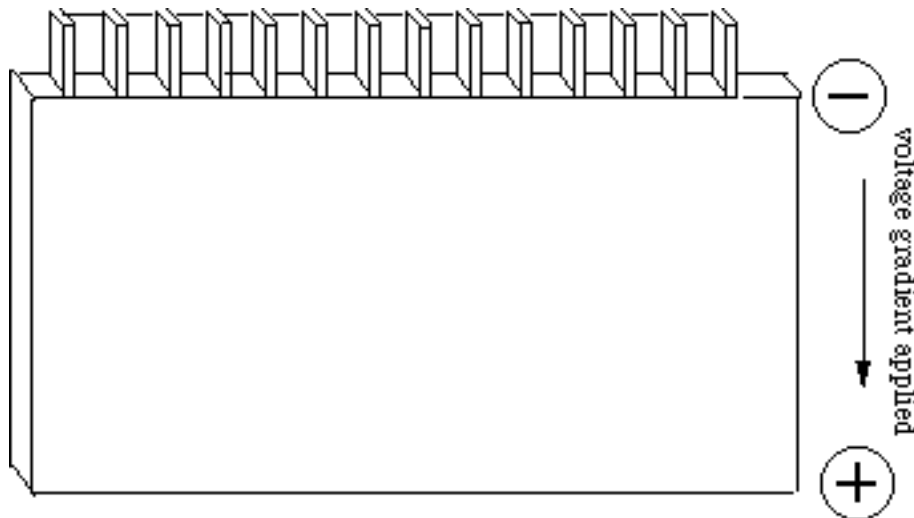

- b. If each lane represents the proteins from a different species of animal, which two would you say are the most closely related? Why?
3. If two proteins have the same molecular weight are they necessarily the same protein? Explain.

Name: \_\_\_\_\_ Date: \_\_\_\_\_

## Lab Report Sheet

### Post-Lab Questions

1. Restate the question your group was asking.
2. Describe or sketch the initial appearance of the gel.
3. Describe or sketch the appearance of the gel after 5 minutes. Explain the difference between the “just loaded” gel and the gel after 5 minutes.
4. After the staining and destaining procedure is done, observe the bands on the gel and make a sketch of your gel. Be sure to indicate the positive and negative sides of the gel and label each lane, indicating which sample was loaded into it.
- 5a. Based on your analysis of the gel, which organisms are closely related?
  - b. Which organisms are distantly related? How do you know?
6. Discuss the results of your experiment in light of the question you asked.
7. (optional) It is possible to determine the size of individual proteins by comparing their distance migrated on a gel to the distances moved by proteins of known size. The distance migrated is inversely related to the log of the size.
  - a. From your gel photo (or from the gel itself) measure the distance from the well to each of the bands in the lane corresponding to molecular weight markers.
  - b. Obtain a piece of 2 cycle semi-log paper. For each band, plot the distance migrated from the well on the linear axis and the size (molecular weight) on the log scale. Connect the points with a smooth curve. This is a standard curve and can be used to determine the size of any of the proteins separated from your muscle tissues. Conditions vary from gel to gel, this is why it is very important to include molecular weight markers on every gel that you run. You cannot use a set of molecular weight markers from another gel in your class to determine the size of proteins on your gel. Determine the size of several of the most abundant proteins in each of your samples.
8. An amino acid is approximately 120 Daltons. Use this information to calculate the approximate number of amino acids in the proteins you sized in part b.

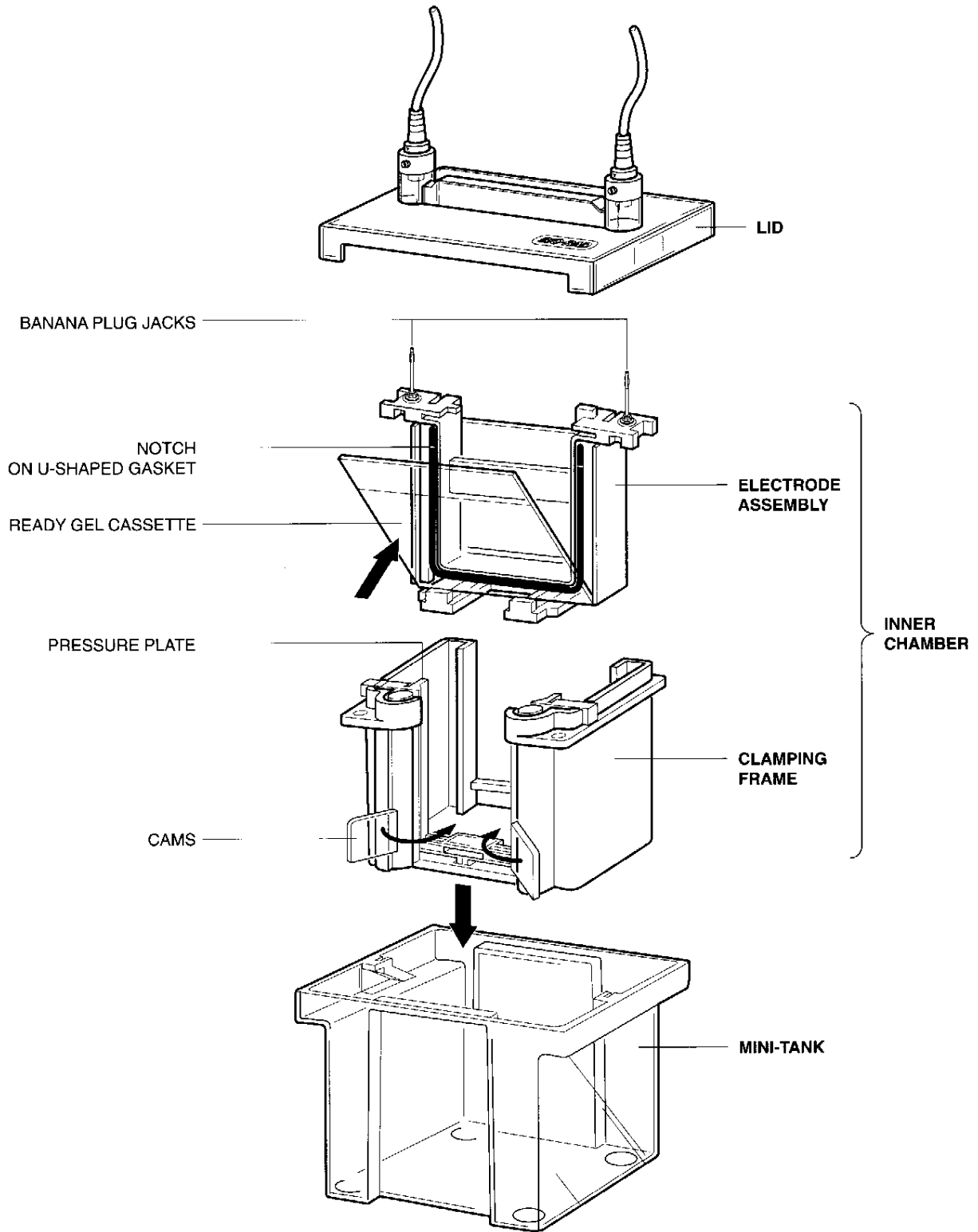

### Gel Box Assembly

From Bio Rad's Ready Gel Cell Instruction Manual, p.4